

ML4022-MCB (SFP-DD) Datasheet

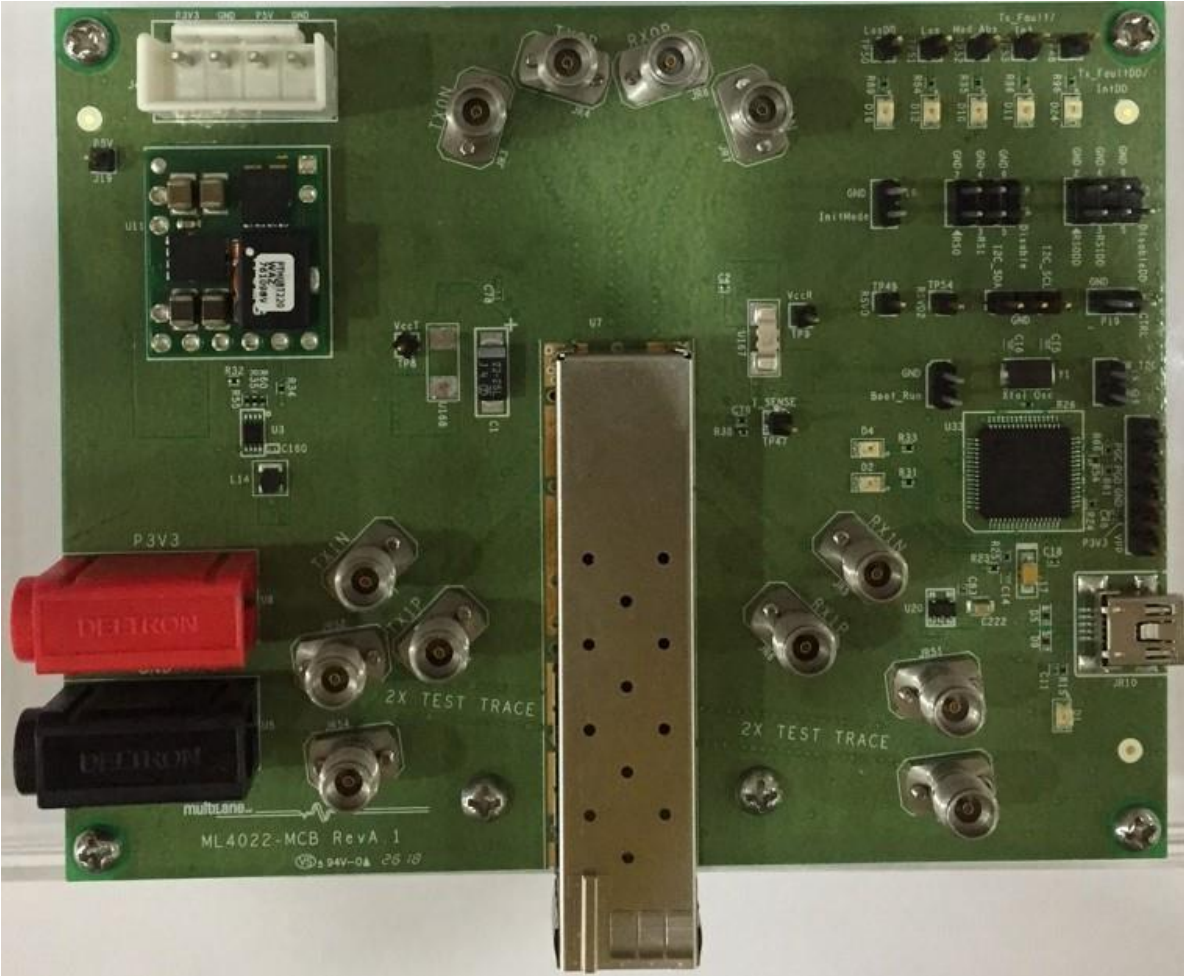

Revision 1.0

Table of Contents

1.	<i>Board features</i>	3
2.	<i>Power up and operation</i>	3
3.	<i>Operating conditions</i>	3
4.	<i>LED indicators</i>	3
5.	<i>SFP-DD HW signaling</i>	4
6.	<i>Software description</i>	5
6.1	Communication	5
6.2	Channel monitor.....	5
6.3	Host Monitor	7
6.4	Module output	8
6.5	Module input.....	8
6.6	Rate select.....	8
6.7	Reserved pins	8
6.8	I2c R/W	9
6.9	Bulk I2C R/W	9
APPENDIX	10
	Bootloader	10
	Revision history.....	10

1. Board features

- ✓ support two lanes that operate up to 50 Gbps each
- ✓ I2C master driven from both on board microcontroller or external pin headers
- ✓ Current sense
- ✓ Controllable module voltage where 3 options are available: 3.15V, 3.3V and 3.45V (depending on voltage supply and the populated SMT jumper: U167 OR U168)
- ✓ Matched differential trace length
- ✓ High performance signal integrity traces from K connectors to SFP-DD host connector
- ✓ On-board LEDs display MSA output states
- ✓ On-board jumpers/ pin headers for MSA external control signals
- ✓ USB interface

2. Power up and operation

To power up the SFP-DD host, steps are as follow:

- The host TOP is where the cage is mounted
- Two options are available to power up the board:
 - using the four pins power connector (J43) that should be connected to 5V AND 3.3V taking into account pins distribution, where jumper U138 must be populated
 - by plugging the banana plugs to 3.3V where jumper U137 must be populated
- Connect the host to your PC using a type-B mini to type-A USB cable

3. Operating conditions

Parameter	Symbol	Conditions	Min	Typical	Max	Unit
+5V	P5V	Supply from J43 (+5V)	-	5	-	V
+3.3V	P3V3	Supply from J43 OR banana plugs U5 and U6 (+3.3V)	3.135	3.3	3.465	V

4. LED indicators

The LED D1 indicates whether a USB cable is plugged or not.

Two other LEDs, D2 and D4, colored green and red, respectively, are used for diagnostic purposes.

- If D2 is on: USB is locked and device is recognized by the USB driver
- If D4 is on: USB is not connected or USB driver is not found
- If both are off: board is not powered correctly or firmware is corrupted
- If both are blinking: the board is in Bootloader mode

5. SFP-DD HW signaling

I2C pins can be accessed using pin headers (U152); jumper should be placed on pin header J2 (HW_I2C) as shown in the figure.

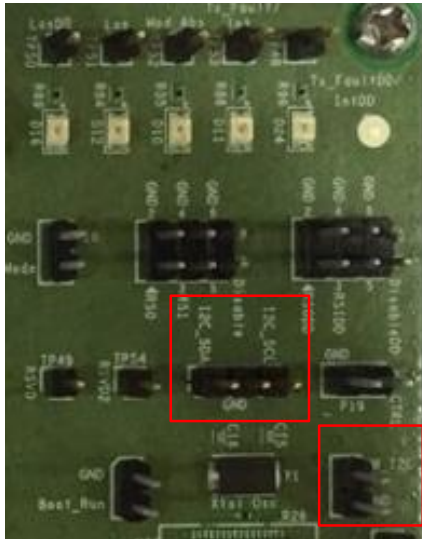

Hardware alarm and control pins can be accessed through pin headers; also a jumper is required to be placed on pin header P19 (HW_CTRL) as shown here.

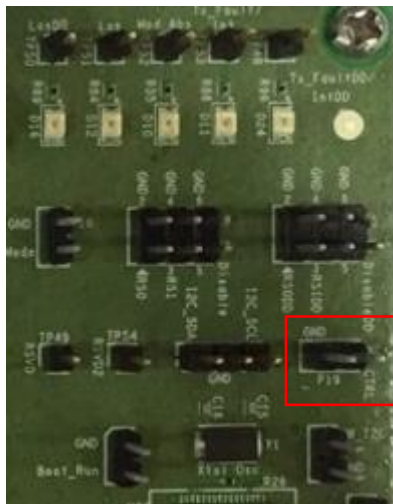

- a) Controlled signals using jumpers: RS0, RS1, Tx_Disable, RS0DD, RS1DD, Tx_DisableDD, InitMode.
These pins are high (pulled-up) by default, forced to low when jumpers are connected.
- b) Alarm signals accessed through pin headers with LEDs indicators: MOD_ABS, LOS, LOSDD, Tx_Fault/Int, Tx_FaultDD/IntDD.
These signals are high (pulled-up), when module is inserted and operating normally these signals are asserted low.
- c) Controlled signals using pin headers only: RSVD, RSVD2.
These pins can be high, low or tri-stated.

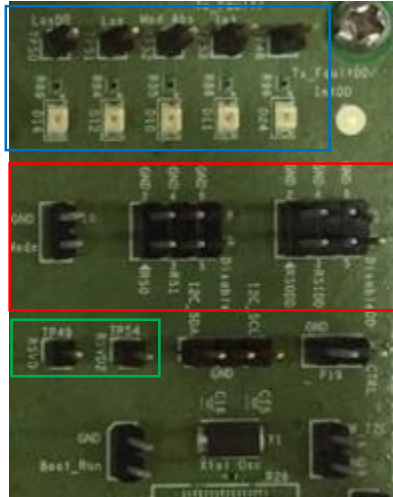

6. Software description

The Host and the module are controlled using a GUI; a user friendly interface that allows the user to monitor general data, control signals, read alarm status and access registers, etc...

A brief description of blocks is described in the following sections

6.1 Communication

In this box, user can select the USB instance, and initialize the communication with the host.

At the right a status indication is available for Module found/Not found and USB connected / Error

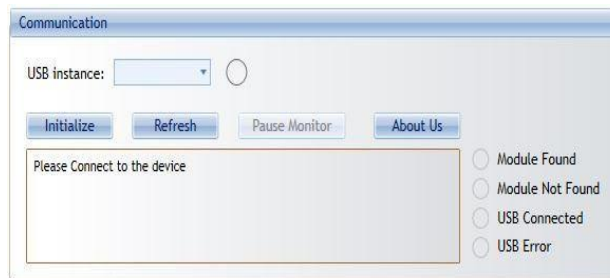

6.2 Channel monitor

The Channel Monitor Box shows Alarms and warnings Flags for the listed parameters, in addition to measurements values for the same parameters list.

There is two identical monitor boxes, one for each Lane.

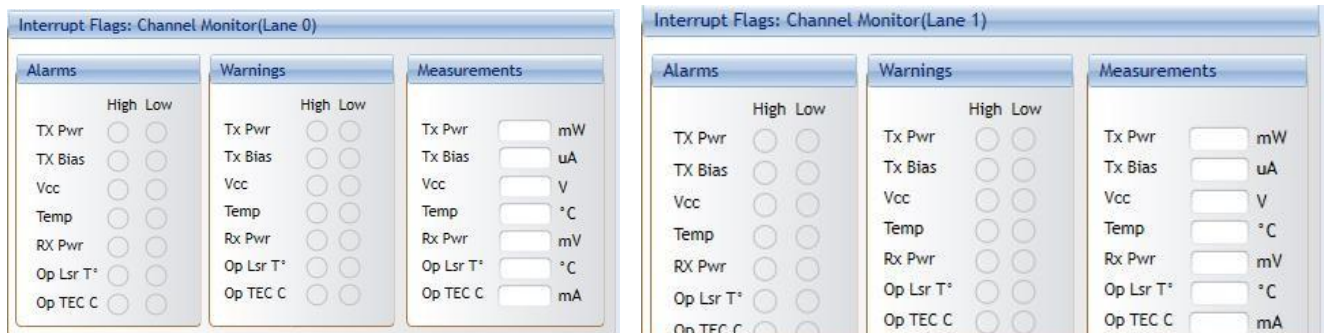

The registers map of the alarms, warnings and measurements in the MSA are shown in the following tables:

All registers are in Address **A2h**

Lane 0 Byte	Lane 1 Byte	Bit	Name
112	240	7	Temp High Alarm
		6	Temp Low Alarm
		5	Vcc High Alarm
		4	Vcc Low Alarm
		3	TX Bias High Alarm
		2	TX Bias Low Alarm
		1	TX Power High Alarm
		0	TX Power Low Alarm
113	241	7	RX Power High Alarm
		6	RX Power Low Alarm
		5	Optional Laser Temp High Alarm
		4	Optional Laser Temp Low Alarm
		3	Optional TEC current High Alarm
		2	Optional TEC current Low Alarm
116	244	7	Temp High Warning
		6	Temp Low Warning
		5	Vcc High Warning
		4	Vcc Low Warning
		3	TX Bias High Warning
		2	TX Bias Low Warning
		1	TX Power High Warning
		0	TX Power Low Warning
117	245	7	RX Power High Warning
		6	RX Power Low Warning
		5	Optional Laser Temp High Warning
		4	Optional Laser Temp Low Warning
		3	Optional TEC current High Warning
		2	Optional TEC current Low Warning

Measurements table:

Lane 0 Byte	Lane 1 Byte	Bit	Name	Description
Converted analog values. Calibrated 16 bit data.				
96	224	All	Temperature MSB	Internally measured module temperature.
97	225	All	Temperature LSB	
98	226	All	Vcc MSB	Internally measured supply voltage in transceiver.
99	227	All	Vcc LSB	
100	228	All	TX Bias MSB	Internally measured TX Bias Current.
101	229	All	TX Bias LSB	
102	230	All	TX Power MSB	Measured TX output power.
103	231	All	TX Power LSB	
104	232	All	RX Power MSB	Measured RX input power.
105	233	All	RX Power LSB	
106	234	All	Optional Laser Temp/Wavelength MSB	Measured laser temperature or wavelength
107	235	All	Optional Laser Temp/Wavelength LSB	
108	236	All	Optional TEC current MSB	Measured TEC current (positive is cooling)
109	237	All	Optional TEC current LSB	

6.3 Host Monitor

The Host Monitor shows the current consumption on Tx and Rx, the host voltage and the host temperature

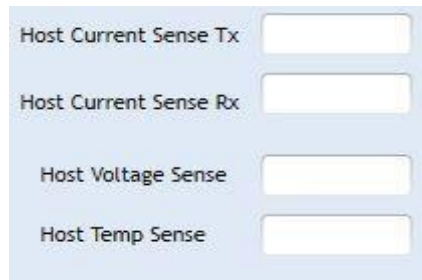

Host Current Sense Tx

Host Current Sense Rx

Host Voltage Sense

Host Temp Sense

6.4 Module output

The signals shown are:

TxFault/TxFault1: Transmitter fault indication for SFP/SFP-DD respectively.

RxLOS/RxLOS1: Loss of signal for SFP/SFP-DD

ModABS: module absent indicator

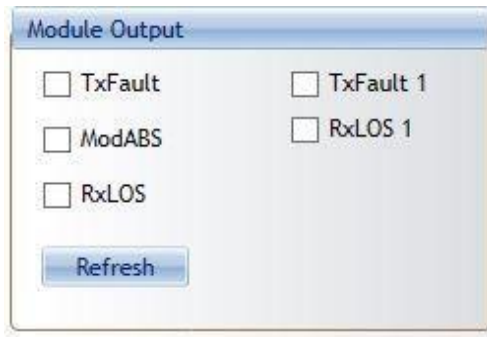

Signals should be unchecked in normal operation.
Checked: high.
Unchecked: low.

6.5 Module input

The Module input signals are:

TxDisable/ TxDisable1: Transmitter disabled for SFP/SFP-DD respectively

InitMode: initialization mode control

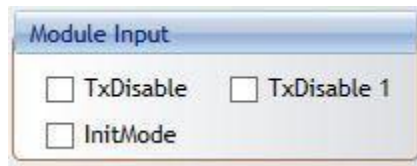

Default is low
Checked: high.
Unchecked: low.

6.6 Rate select

Pins are used to control the Rate:

RS0-1/2: LOW-RX low rate
High-RX high rate

RS1-1/2: LOW-TX low rate
High-TX high rate



Default is low
Checked: high.
Unchecked: low.

6.7 Reserved pins

General purpose pins that allow user to choose the specific logical level for each separately

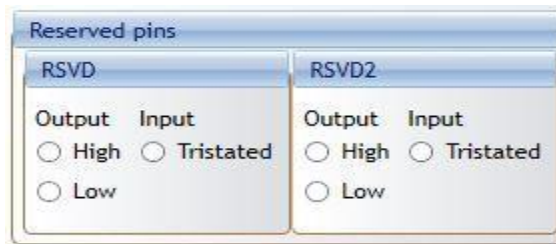

6.8 I2c R/W

In the I2C R/W box user can:

- 1- Select the slave address
- 2- Select the memory page
- 3- Single byte R/W and data format display
- 4- Multi-bytes R/W from start to end address

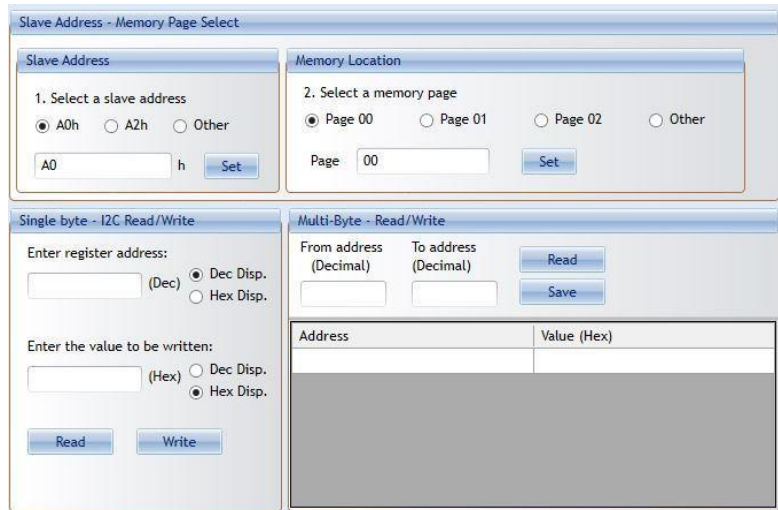

6.9 Bulk I2C R/W

As shown in the figure below, the GUI include a window that allows user to deal with MSA file.

User is capable to choose the list of addresses to display, read these addresses and edit its contents in addition to save a copy of the edited MSA to user's files. Also user can load an MSA from files and to write the MSA to hardware.

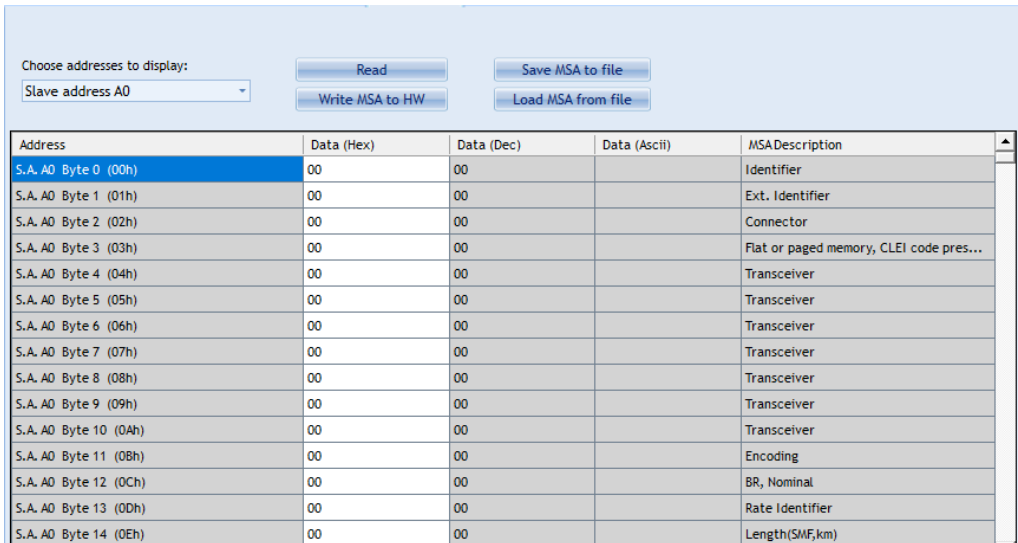

APPENDIX

Bootloader

You can access the bootloader to reprogram the microcontroller, to do that, simply:

1. Connect a jumper on (J1) Boot_Run.
2. Connect a USB cable between the PC and Board.
3. Power up the board.
4. LEDs (D2, D4) start blinking.
5. Remove jumper.
6. Open the software “Microchip USB HID Bootloader v2.3”.
7. Click on “Open Hex File”.
8. Choose the target FW to download.
9. Click on “Program/Verify”.
10. Once the software finishes programming press on “Reset Device”.
11. After reset the Firmware is successfully updated.

Revision history

Date	Revision	description
12/12/2018	V1.0	Initial version

North America

48521 Warm Springs Blvd. Suite 310
Fremont, CA 94539
USA
+1 510 573 6388

Worldwide

Houmal Technology Park
Askarieh Main Road
Houmal, Lebanon
+961 5 941 668

Asia

14F-5/ Rm.5, 14F., No 295
Sec.2, Guangfu Rd. East Dist.,
Hsinchu City 300, Taiwan (R.O.C)
+886 3 5744 591