

Innovation for the next generation

ML4015D

Optical and Electrical Sampling Oscilloscope

Ideal for 25G NRZ and 26.6 GBaud PAM4 transceiver testing | Supports 802.3 TDECQ measurements via SSPRQ patterns | Open Eye MSA support



Summary

The characterization of Ethernet transceivers introduces a myriad of test and measurement challenges. For instance, precise validation of 26 GBaud PAM4 optical transmitters requires prohibitively expensive instrumentation setups for production applications. MultiLane introduces the ML4015D Optical and Electrical Sampling Oscilloscopes as a well-correlated alternative to incumbent solutions at a high-value price point.

MultiLane's ML4015D Optical Sampling Oscilloscope is offered as a complement to its BERT, Optical Clock Recovery, Optical Switch Box, consumable MCB and ML7007 software automation framework products. This turnkey solution suite is proven to enable high volume characterization and manufacturing of optical transceivers.

ML4015D

Optical and Electrical DSO

Introduction

The ML4015D is a fully featured, cost effective single channel sampling oscilloscope. It can be configured to have an optical bandwidth of either 25 or 40 GHz. The supported wavelengths range from 1260 to 1650 nm single mode or 700 to 870 nm multimode. The ML4015D can also be configured with either a 32 or 50 GHz differential electrical sampler.

Key Features

The ML4015D family of optical DSOs boast an extensive set of features and functions that are unique in the industry. These include:

- A noise floor of 5 μ W at an analog bandwidth of 25 GHz, and 6-7 μ W at 40 GHz bandwidth.
- Sensitivity level of -11 dBm for a 25.78 Gbps NRZ signal.
- Up to 50 - 70 MHz sampling rate.
- Less than 15 seconds TDECQ on a SSPRQ pattern.
- FPGA-based architecture enabling TDECQ measurements via capture of SSPRQ and PRBS16 patterns.
- An extensive library of built-in DSP filters such as Bessel-Thomson, CTLE, DFE, FFE, de-embedding, and component emulation, all available free of charge in the standard GUI.
- Comprehensive eye mask library.
- Individual impulse response calibration performed at factory.
- Compact instrument footprint with a ruggedized enclosure and handle.
- Comprehensive set of APIs and associated sample scripts to accelerate automation development under Linux and Windows, supporting Python, LabView, Matlab, and C#.

Typical Optical Applications

- Production/manufacturing testing of 1G to 400G optical transceivers.
- Benchtop characterization of optical circuits.
- Qualification of PAM-N and NRZ optical modulators and drivers.
- Sensitivity testing of optical receivers.
- System testing with ML1016D-CR clock recovery.

Typical Electrical Applications

- TP1a stress calibration.
- SERDES characterization.
- Receiver electrical output characterization.
- Benchtop characterization of electrical circuits.

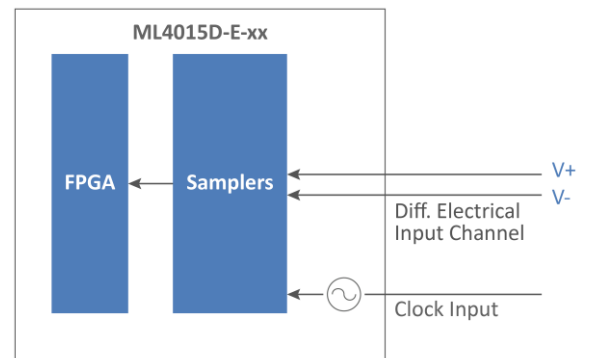

Figure 1: Schematics of the ML4015D-E-xx

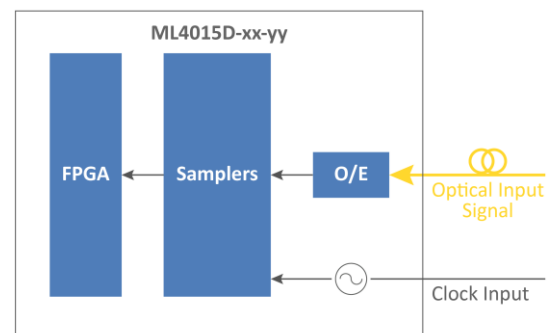

Figure 2: Schematics of the ML4015D-xx-yy

Optical Specifications

Parameter	Specifications
SM Wavelength	1260 - 1650 nm
MM Wavelength	700 - 870 nm
Calibrated wavelengths	1310 and 850 nm
Optical bandwidth	25 or 40 GHz
Noise RMS at 1310 nm	5 μ W at 25 GHz 6 - 7 μ W at 40 GHz
Sensitivity at 1310 nm at 25.78 G NRZ	< -11 dBm
Intrinsic jitter	200 fs rms
Input Power damage level	10 dBm
Fiber Input SM	9 / 125 μ m
Fiber Input MM	50 / 125 μ m
Connector	FC PC
Analog Sampling Hardware Resolution	14 bits
Clock input bandwidth	0.1 - 4.4 GHz
Clock input swing	225-1800 mVpp
Clock input connector	SMA (f), 50 Ω
Pattern capture	> 8 M Samples
Sampling frequency	50 - 70 MHz
Memory	8 MSa
Pattern Lock	Up to PRBS16, SSPRQ
Temperature range	0 - 75 $^{\circ}$ C
Line Power	100 - 240 V AC, 50 / 60 Hz

Electrical Specifications

Parameter	Specifications
Electrical amplitude	< 600 mV SE and < 1200 mV Diff
Electrical bandwidth	32 or 50 GHz
Intrinsic jitter	200 fs rms
Electrical channel Connectors	2.92 or 2.4 mm
Analog Sampling Hardware Resolution	14 bits
Clock input bandwidth	0.1 - 4.4 GHz
Clock input swing	225 - 1800 mVpp
Clock input connector	SMA (f), 50 Ω
Pattern capture	> 8 M Samples
Sampling frequency	50 - 70 MHz
Memory	8 MSa
Pattern Lock	Up to PRBS16, SSPRQ
Temperature range	0 - 75 $^{\circ}$ C
Line Power	100 - 240 V AC, 50 / 60 Hz

Supported DSP Functions

- Frequency response correction of O/E & analog front end.
- Nth-Order Bessel-Thomson.
- CTLE adaptive or manual.
- FFE adaptive or manual.
- DFE adaptive or manual.
- De-embedding or embedding of four-ports (.s4p) and two-ports (.s2p) files.
- Moving average.

Supported Measurements

Coding	Measurement
PAM-4	TDECQ
	SNDR
	Open Eye MSA
	RLM
	OMA _{outer}
	Eye Height by BER
NRZ	Eye Width by BER
	Top & Base
	Min & Max
	One & Zero
	Transition Time
	Crossing %
	AOP
	OMA
	Mask
	Peak to Peak
	Eye Amplitude
	Eye Height
	Eye Width
	Jitter
	SNR
	ER
	VEC
	Vrms
	DJ & RJ
	Noise

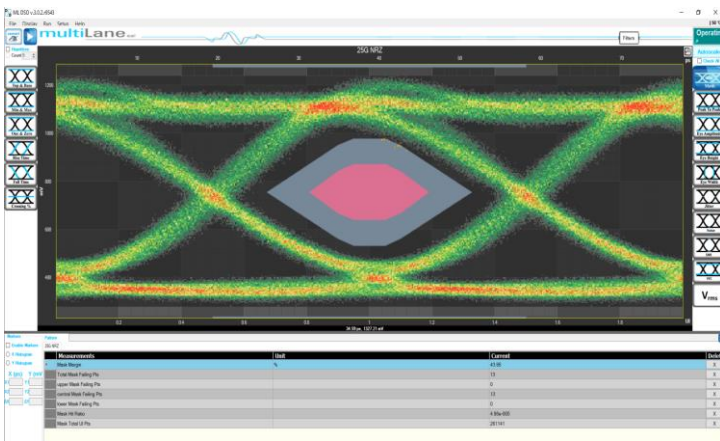

Figure 3: Mask Margin at 25G NRZ

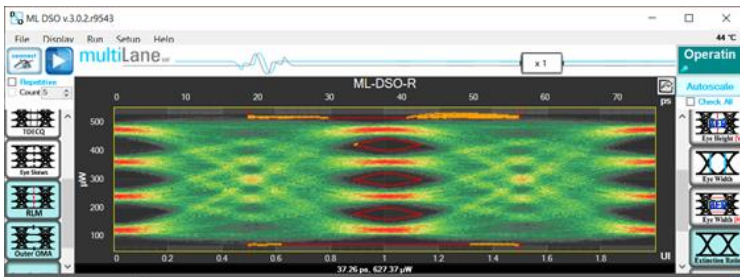

Figure 4: 26.5625 GBaud optical eye diagram – Open Eye MSA

Measurements	Unit	Current	D
OMA(outer)	μW	340.62	X
OMA(outer)_Level3	μW	463.21	X
OMA(outer)_Level0	μW	122.59	X
OMA(outer)	dBm	-4.68	X
Open Eye MSA DC Balance		0.0707	X
Open Eye MSA Inter Eye Skew	UI	0.00	X
Open Eye MSA Symbol Symmetry		0.96	X
Open Eye MSA EFlow	% OMA Outer	12.43	X
Open Eye MSA EFlow	% OMA Outer	11.46	X
Open Eye MSA EFlow	% OMA Outer	10.36	X
Open Eye MSA EFlow	UI	0.26	X
Open Eye MSA EFlow	UI	0.26	X
Open Eye MSA EFlow	UI	0.23	X
Open Eye MSA VEC Deterministic	dB	0.3107	X
Open Eye MSA VEC Statistical	dB	1.09	X
Open Eye MSA Mask Failing Points		453.00	X
Extinction Ratio (outer)	dB	5.89	X
RLM/IEEE 802.3 clause 94)		0.96	X
RLM/IEEE 802.3 Annex 120D)		0.93	X

Filter CTLE configured and applied 1048K Sample/UI Acquisition 1

Figure 5: Supported Open Eye MSA measurements

Triggering ML4015D using ML1016D-CR Optical Clock Recovery Module

The ML1016D-CR is a 26.5625 GBd PAM4 Optical Clock Recovery Module ideally suited for 50G per wavelength optical measurements. The recovered clock can trigger the ML4015D Optical Scope to perform 26.5625 GBd PAM4 optical measurements such as TDECQ, OMA, and ER. In addition, standards with 25.78 Gbps NRZ signaling format, such as 100GBASE-LR4, PSM4, CWDM4, and SR4, are supported.

Test Setup Using ML4015D

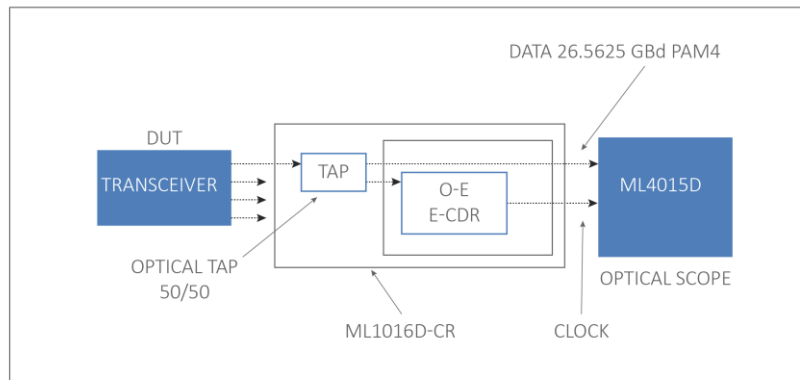

Figure 6: Functional block diagram of the ML1016D-CR + ML4015D-SM

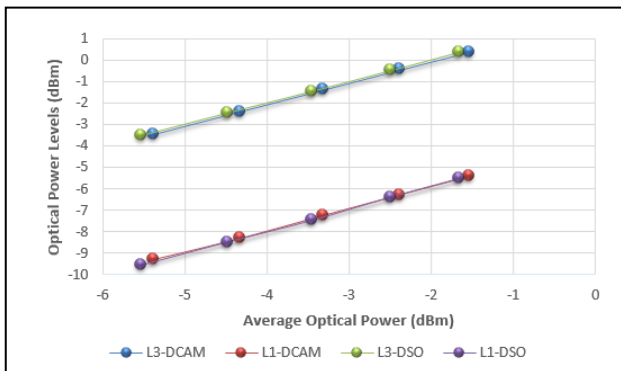

Figure 7: L1 and L3 comparison

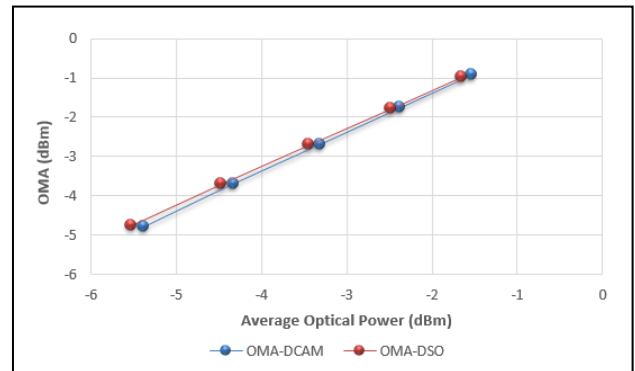

Figure 9: OMA-DCAM and OMA-DSO comparison

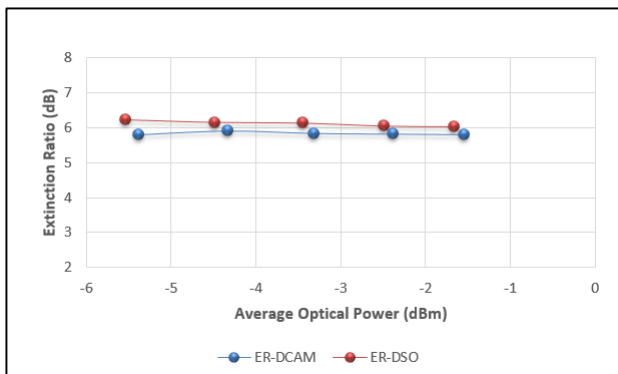

Figure 8: ER-DCAM and ER-DSO comparison

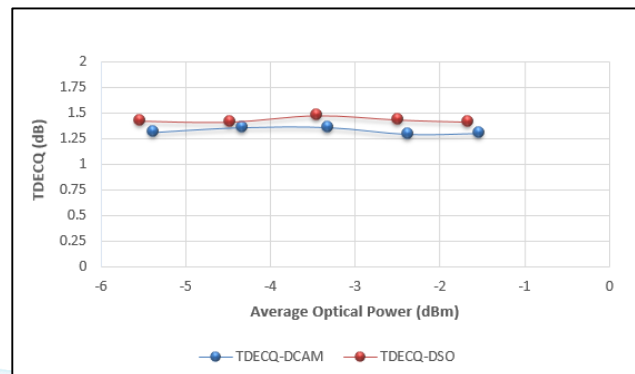
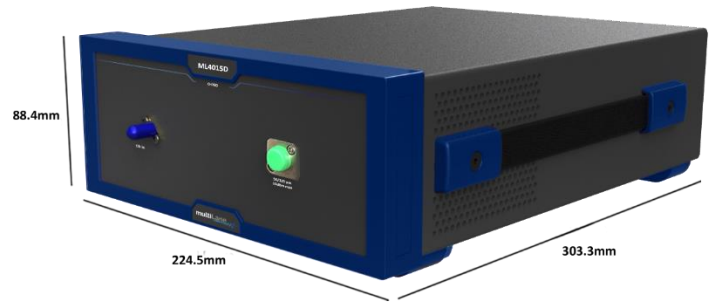

Figure 10: TDECQ-DCAM and TDECQ-DSO comparison

Mechanical Dimensions

The ML4015D is a benchtop instrument that also fits in a 19-inch 2U rack. It has a ruggedized Enigma enclosure with improved mechanical rigidity. Two ML4015Ds arranged side by side comprise one 2U slot in the rack. MultiLane also supplies the needed bracket.



Ordering Information

Part Number	Description
ML4015D-	
25-SM	25 GHz optical, single-mode fiber
25-MM	25 GHz optical, multi-mode fiber
40-SM	40 GHz optical, single-mode fiber
E-32	32 GHz electrical
E-50	50 GHz electrical
E-50-24	50 GHz electrical, 2.4 mm connectors
3YW	3-year warranty
CAL	Single calibration
3YWC	Total 3-year warranty with 3 annual calibrations

Recommended Accessories

Instruments	Recommended cables	Comments
ML4015D-25-SM	1x MLCBPS-2.92-30/60	2.92 mm connector, Clock Input Cable, 30 or 60 cm
ML4015D-25-MM	1x MLCBPS-2.92-30/60	2.92 mm connector, Clock Input Cable, 30 or 60 cm
ML4015D-40-SM	1x MLCBPS-2.92-30/60	2.92 mm connector, Clock Input Cable, 30 or 60 cm
ML4015D-E-32	1x MLCBPM-2.92-30/60, 1x MLCBPS-2.92-30/60	2.92 mm connector 2x1 channel, 30 or 60 cm, and 2.92 mm connector for Clock Input, 30 or 60 cm
ML4015D-E-50	1x MLCBPM-2.92-30/60, 1x MLCBPS-2.92-30/60	2.92 mm connector 2x1 channel, 30 or 60 cm, and 2.92 mm connector for Clock Input, 30 or 60 cm
ML4015D-E-50-24	1x MLCBPM-2.4-30/60, 1x MLCBPS-2.92-30/60	2.4 mm connector 2x1 channel, 30 or 60 cm, and 2.92 mm connector for Clock Input, 30 or 60 cm

Please contact us at sales@multilaneinc.com.



North America

48521 Warm Springs Blvd. Suite 310
Fremont, CA 94539
USA
+1 510 573 6388

Worldwide

Houmal Technology Park
Askarieh Main Road
Houmal, Lebanon
+961 81 794 455

Asia

14F-5/ Rm.5, 14F., No 295
Sec.2, Guangfu Rd. East Dist.,
Hsinchu City 300, Taiwan (R.O.C)
+886 3 5744 591