

The superPal for 11ax, Bluetooth test

octoScope's superPal® is an 802.11ax, legacy 802.11 and Bluetooth test instrument that functions as an expert analyzer, traffic partner, virtual station emulator and a load generator for testing throughput, capacity, roaming, band steering and more. It also integrates the interference generation capabilities of octoScope's iGen®.



Figure 1: superPal module

Each of the 802.11ax radios in the superPal can function as an access point (AP), a station (STA), virtual stations (vSTAs), a traffic partner, a load generator, a sniffer or an expert analyzer for powerful device and system level tests. The Bluetooth (BT) radios can be sniffers or partners for testing Bluetooth 5, BTLE or legacy devices. The superPal can be used in the controlled RF environment of the octoBox® personal testbed or as a stand-alone instrument.

FEATURES

- 802.11ax up to 8x8 MIMO-OTA transmission
- 2.4 and 5 GHz 802.11ax and legacy radios and two BT 5.0, BLE, BLE 2 GHz EDR, SCO and eSCO
- BT profiles: A2DP, OPP, HFP, HID, BLE HID
- Wireshark synchroSniffer™ with a sniffer probe on each of the 4 radios for simultaneous Wi-Fi and Bluetooth sniffing
- Up to 64 virtual Wi-Fi stations, vSTAs
- Expert analysis of PCAP captures
- Interference generation
- Complete isolation from outside interference
- Powerful test automation API
- Seamless integration with the octoBox personal testbed

BENEFITS

- Quickly and easily verify emerging 802.11ax and legacy Wi-Fi devices in the ideal 8x8 MIMO-OTA environment
- Using the octoBox personal testbed perform key tests including throughput vs. range vs. orientation, roaming, band steering, coexistence, WFA certification and more
- Test BT/Wi-Fi coexistence
- Test BT pairing with BT 5, BTLE and legacy devices
- Perform root cause analysis of poor performance or protocol issues using built-in multi-probe multi-channel expert analysis
- Test capacity of APs with 64 concurrent virtual stations; application layer traffic

SUPERPAL ARCHITECTURE

Based on the latest 802.11ax chipsets and with fine controls at the firmware and driver level, the superPal can function as a real device or as a precision test instrument. For example, to test band steering, the superPal can function at a set data rate, bandwidth and number of streams. To test receiver sensitivity, the superPal can operate at a fixed modulation coding scheme (MCS).

The superPal features two 802.11ax radios. The 5 GHz radio supports up to 8x8 MIMO in channels of up to 80 MHz, or 4x4 MIMO in 80+80 or 160 MHz channels.

The superPal has two BT 5, BTLE radios to test Bluetooth and to capture sniffer traces.

A built-in synthesizer emulates interference, such as radar for DFS testing, microwave ovens, baby monitors, phones, and more.

To address the high bandwidth requirements of 802.11ax, the superPal features two 10 GbE ports.

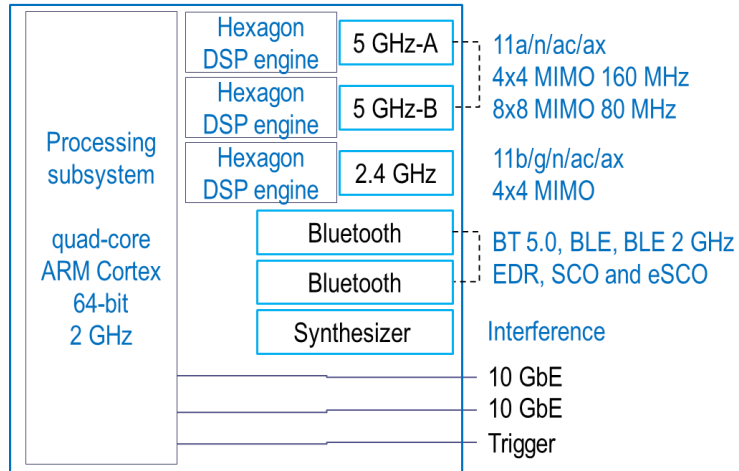

Figure 2: superPal block diagram; chipsets used are Qualcomm Hawkeye QCN5054/QCN5024 and Cypress CYW20719



EXPERT ANALYSIS

The superPal can function as a real-time analyzer to show adaptation behavior of modern Wi-Fi systems. It can monitor and plot RSSI, data rate, number of spatial streams, channel width and other physical layer information.

AP TESTING

To test access point (AP) performance or to emulate a realistic network with multi-station traffic, the superPal can emulate up to 32 vSTAs (virtual stations) per-radio, up to 64 virtual stations per superPal.

Real-life traffic can be bridged from the Ethernet interface via each vSTA to test video, voice and data performance with different priority and security settings.

STATION TESTING

To test a station device, configure the superPal radios as APs, so they can be traffic partners to the station under test. The radios can also be sniffers or expert analyzers. Station tests include throughput vs. range vs. orientation, RX sensitivity, data rate adaptation performance, roaming, band steering, and more.

SYNCHROSNIFFER

superPal can capture and stream packets in the PCAP format to the Wireshark in real-time. Each radio on the superPal can be synchronized with the radios on the same or other superPals or Pals via Precision Time Protocol (PTP). The captures from each radio in the octoBox testbed are combined in a common PCAP file viewable in the octoScope-customized Wireshark for easy analysis. In this custom Wireshark application, you can identify captures by probe (i.e. superPal or Pal radio). Such a common view of the different points in the testbed helps analyze complex band steering, roaming and mesh behavior in the presence of motion, interference, path loss, multipath and variable orientation of the DUT.

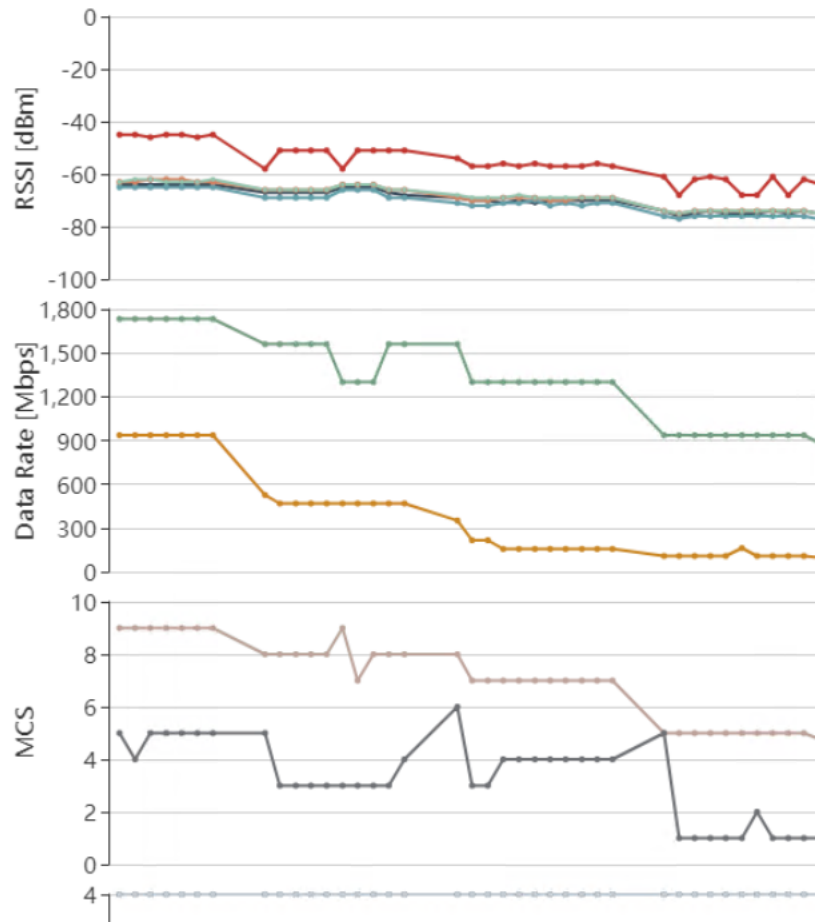

BLUETOOTH TESTING

Bluetooth testing includes:

- Pairing test of BT 5, BTLE and legacy devices
- Master and Slave modes for pairing and traffic testing
- BT sniffer on 2 Bluetooth radios simultaneously, synchronized with captures from Bluetooth or Wi-Fi radios on any octoScope Pals
- BT traffic partner to the DUT
- HID latency
- AFH map
- Configurable packet size
- Simultaneous BT and Wi-Fi traffic
- Powerful test automation API

TESTING IN THE PRESENCE OF INTERFERENCE

To emulate in-range networks that contribute to co-channel and adjacent channel interference (CCI and ACI), the superPal can replay saved PCAP files in a special replay mode without requiring association to transmit this traffic load.

The superPal can also generate waveform interference, enabling tests of throughput and other wireless metrics in the presence of interference.

The waveform interference generator also enables testing in the presence of radar signals in the 5 GHz band (DFS testing.)

SUPERPAL IN AN OCTOBOX PERSONAL TESTBED

The superPal enables compact yet powerful octoBox personal testbeds with a range of automated tests.

A block diagram of the octoBox testbed with Pals and a superPal is shown in Figure 3.

A photo of the system in the block diagram is shown in figure 4.

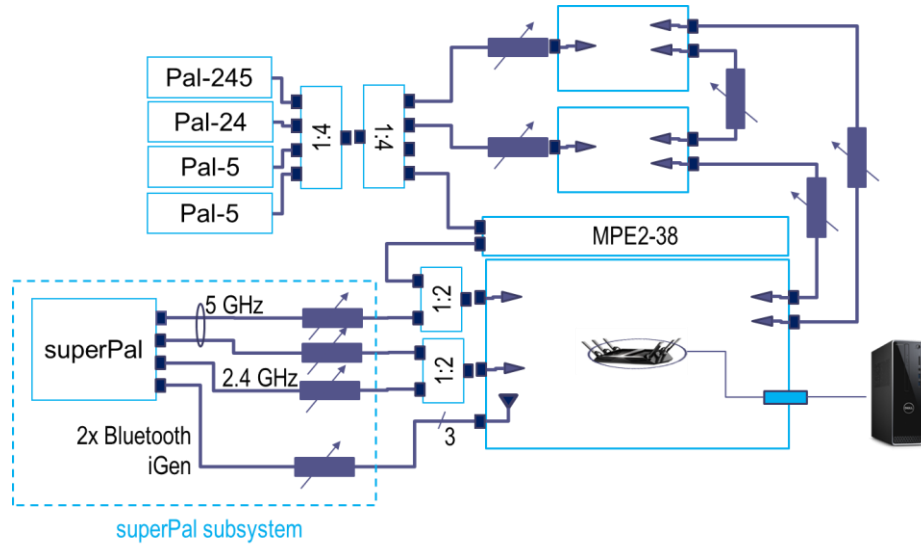

Figure 3: STACK-MESH with superPal



Figure 4: STACK-MESH with Pals

SUPERPAL SPECIFICATIONS

Wi-Fi	
Channels	2.4 GHz and 5 GHz; tri-band
Bandwidth	20, 40, 80, 80+80, 160 MHz
Standards	801.11a, 802.11b, 802.11g, 802.11n, 802.11ac (wave 2), 802.11ax
Virtual stations	32 per-radio, 64 total
Traffic replay	From PCAP file
Monitor	Detailed statistics from the Wi-Fi chipset
Sniffer	Wireshark captures
802.11ax PHY	Downlink OFDMA Uplink OFDMA Single user MIMO with > 1 spatial stream Downlink multiuser MIMO Uplink multiuser MIMO DL and UL single user transmit beamforming DL OFDMA + transmit beamforming
802.11ax MAC	Trigger frame support Non-trigger based and trigger-based sounding for beamforming Multi-user RTS and CTS Buffer status report UL-OFDMA Random Access Multiple BSSID Bandwidth query report
Bluetooth	
Protocols	Bluetooth 5, BLE, BLE 2 Mbps, EDR, SCO and eSCO
Test features	BT Master and Slave modes for pairing and traffic testing, HID latency, AFH map, configurable packet size, simultaneous BT and Wi-Fi traffic
Sniffer	Wireshark captures via synchroSniffer on the same time base as Wi-Fi radios in the same or disparate superPals or Pals in the testbed; simultaneous capture on both BT radios
Interference	
Channels	2.4 and 5 GHz
Bandwidth	20, 40, 80, 80+80, 160 MHz
	Replay traffic captures (PCAP files) with configurable traffic load and priority
	Programmable MCS (modulation coding scheme), WMM (wireless multi media) priority and other settings
	Built-in frequency synthesizer for generating On/Off Keying waveforms in the frequency range of 500 to 6000 MHz

General	
Traffic endpoints	multiPerf®, iperf3
RF connectors	15 SMA connectors for up to 4x4 MIMO operation on each Wi-Fi radio plus 2 Bluetooth/Thread and 1 interference generator
	Trigger out connector for triggering external RF instruments
Control	Ethernet
Power	Power adapter
Dimensions	23" x 10.4" x 1.4" (58 x 26 x 3.5cm)
TX power	MCS, # stream, frequency and channel width dependent
Processor subsystem	quad-core, ARM Cortex 64-bit, 2 GHz

DIMENSIONS

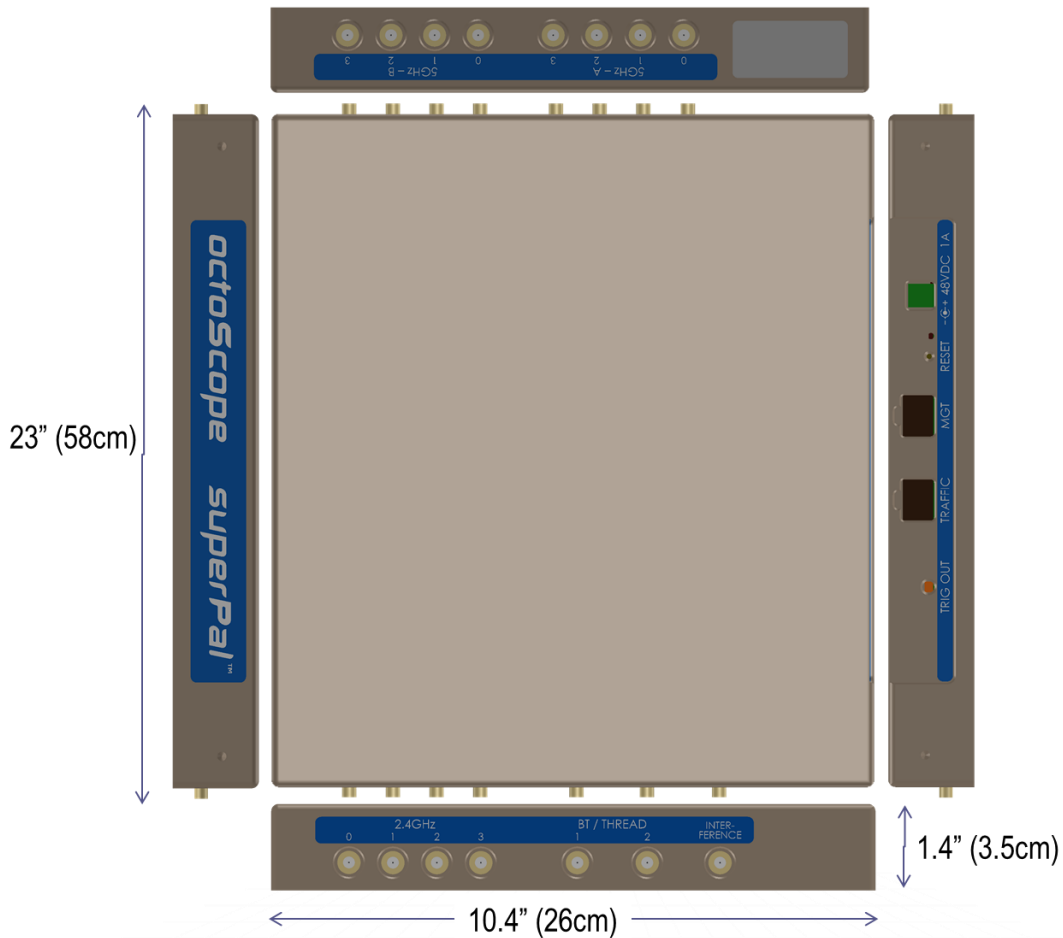

SUPERPAL HARDWARE AND SOFTWARE OPTIONS

Option	Description
OB-SUPERPAL	AP and STA partner, monitoring, interference, single AP/STA bridging; BT pairing
OB-BLUEPAL	Bluetooth testing including Wireshark captures; upgradeable to Wi-Fi capabilities
SW-SNIFFER	Streaming sniffer captures
SW-VSTA	32 vSTAs (virtual stations)
SW-BRIDGE	Bridging capability for each of the vSTAs to run application layer traffic
SW-TRIATHLON	Trigger an RF instrument (e.g. LitePoint) to cross-probe plots, PCAP captures and RF measurements
SW-SPIN	Replay as captured

CONTACT

octoScope
 305 Foster Street
 Littleton, MA 01460
 Tel: +1.978.222.3114
sales@octoscope.com

octoScope
 780 Montague Expressway
 Building 1
 San Jose, CA
 Tel: +1.408.888.0478