

smartoptics

Getting more from dark fiber

The business case for 8G FC embedded DWDM



A Whitepaper from Smartoptics

Of all the methods available for corporate data centers and campuses to connect traffic and replicate data between sites, the majority depend on the availability of a dark fiber network. If fiber is available (either owned or leased) it's possible to run a private network to connect sites together. If it's not available, the choice is limited to a carrier offering a managed service for the number of required channels of Ethernet, storage, voice or video.

This white paper compares individual ELWL (extra-long wavelength) circuits, an active transponder based DWDM solution, and a carrier managed service to a solution based on embedded DWDM.

Each of the scenarios are based on a typical configuration of eight channels of 8Gbps Fibre Channel up to a distance of 40 kilometers over a three year period. In reality, this can be any mix of protocols and all systems lend themselves to be upgraded with more channels as system capacity requirements grow.

Individual ELWL circuits - one fiber per channel

An ELWL circuit (Extra Long Wavelength) is where a single service is run over a dark fiber. Here the ELWL optical transceiver is connected in to the host switch (Ethernet or Fibre Channel) at each site. The output of the transceivers are connected to the line fiber at both ends to create an "end to end connection". Single channel circuits require a fiber for each individual service.

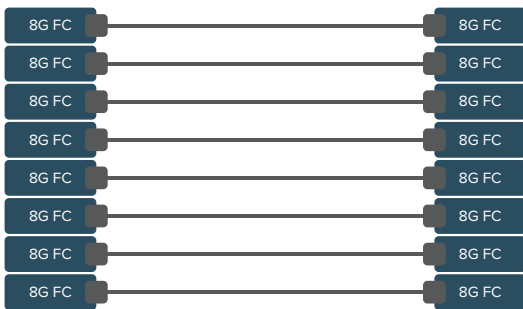

An individual fiber pair and two transceivers needed per channel.

To implement eight ELWL services over a distance of 40 kilometers, eight pairs of fiber need to be leased or purchased together with the corresponding ELWL transceivers. The following calculation is based on 8 x 8Gbps services over a three- year fiber lease period.

Capital expenditure	
16 x 8Gbps-LR SFP+	\$16,000
Operational expenditure	
8 x fiber pair leasing costs	\$288,000
<i>(Based on \$1000 / month leasing cost per fiber)</i>	
TOTAL COST (Three years)	\$304,000

Of all the methods available for corporate data centers and campus networks to connect traffic and replicate data between sites, the majority depend on the availability of a dark fiber network.

While single ELWL channels are simple to setup and the resulting solutions are seemingly low cost, there are a number of fundamental flaws with this approach. The main one being that the fiber asset cannot be shared and is therefore not available for use for any other data traffic. The operating expenses for adding multiple fiber channels also increases linearly per channel. Even though a distance of 40 kilometers is used for the example, it should also be noted that ELWL in practice typically is limited to distances up to 25 kilometers by OEM vendors.

ELWL at-a-glance:

- Plug and play solution
- Low upfront cost per unit
- Individual fiber required for each and every service
- Cost for adding multiple channels increase linearly per channel

Active transponder based DWDM system - multiple channels per fiber

An active DWDM system, also referred to as a transponder-based DWDM system, offers a way of transporting large amounts of data between sites over a single dark fiber network. The transponder takes the output of the SAN or IP switch, usually in a short reach interface (SWL), and converts it from optical short wave to electrical and back to optical DWDM through an OEO conversion. This provides a clear demarcation point between the data layer (Ethernet or Fibre Channel) and the optical DWDM layer.

An active DWDM transponder based system provides a clear demarcation point between the data and the optical layers.

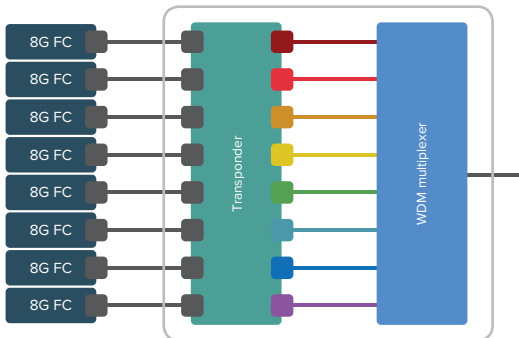

To implement eight DWDM services over a distance of 40 kilometers, a dark fiber needs to be leased or purchased, together with a corresponding DWDM system. The following calculation is based on 8 x 8Gbps services over a three- year fiber lease period.

Capital expenditure	
1 x active DWDM system	\$70,000
Operational expenditure	
1 x fiber pair leasing costs per year	\$12,000
SLA and Software licensing	\$12,000
<i>(Based on \$1000 / month leasing cost per fiber and software licensing)</i>	
Total operating expenses / year	\$24,000
TOTAL COST (Three years)	\$142,000

The reason that a DWDM signal is preferred to a single channel is that many DWDM signals can be connected through a multiplexer and simultaneously transmitted over a single dark fiber network. Therefore geographically separated sites can be connected with fewer fibers. A DWDM signal can also travel much further than a SWL single so DWDM also offers an easy way to go the distance. However, even though these systems can transport huge amounts of data, they tend to be overly complicated and expensive.

Active WDM systems have traditionally been designed with the requirements of dedicated carriers and service providers in mind, catering for the needs of telecom grade networks. In most cases neither the capacities nor the advanced feature-set of a traditional active WDM solution is required for corporate use. This makes an active system unnecessarily complicated to design, install and configure from an enterprise point of view. Most often they are also overly expensive to own and to run.

Active DWDM at-a-glance:

- High-end solution for carrier grade demands
- Powerful, yet fairly complex and expensive platform solution
- DWDM optimizes fiber utilization by allowing several channels to share fiber
- Reduced TCO compared to ELWL

Carrier managed service - leased fiber services

With a carrier managed service, each individual service needs to be leased from the service provider. If eight channels are required, then the same number of managed services needs to be leased. A service contract is typically purchased over a two or three year period. A carrier usually expects a return on investment after six months so this tends to result in a high monthly cost for each and every service. A managed service will achieve the objective of transporting large amounts of data between customer sites but the system will never be owned and paid for. In most cases the platforms are built for telecom-grade networks with additional features that are over the top for corporate data center and campus connectivity.

With a carrier managed service, each individual service needs to be leased from the service provider. If eight channels are required, then the same number of managed services needs to be leased.

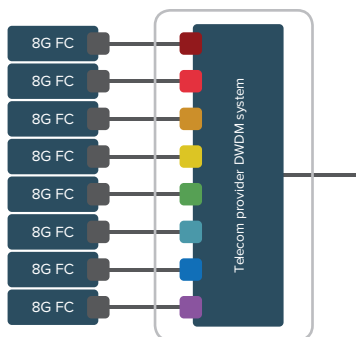

Assumption

Eight channel active DWDM system cost	\$69,730
Monthly lease based on 6 month ROI for carrier	\$11,622

The calculation is based on 8 x 8Gbps managed services leased from a carrier over a three year period.

Operational expenditure

Monthly equipment rental	\$11,622
Monthly fiber rental and service cost (\$1000 / month)	\$8,000

Even though 8 individual services are purchased, these are run as DWDM services over the carriers fiber.

Total operating expenses / year	\$235,464
Total (Three years)	\$706,392
TOTAL COST (Three years)	\$706,392

As the calculation shows, leasing a managed fiber network service from a carrier usually comes at a high price. As the need for new services arise, operating expenses soar. Relying on a leased system, rather than an owned approach also means sacrificing flexibility and the possibility to adjust the service as needs change. Using carrier grade solutions, instead of a platform designed for enterprise use, adds complexity and inflexibility.

Carrier managed service at-a-glance:

- Full service offering removes the need for CAPEX and competence build-up
- Reduced user control, security and flexibility
- Additional channels require new services to be leased
- High TCO due to the operators linear cost structure and short ROI expectations

Embedded DWDM system - plug and play DWDM solutions

An embedded DWDM solution offers the simplicity of the ELWL with the additional advantage that many traffic signals can be transported over the same dark fiber. Upgrading an ELWL system to a DWDM-based solution is about as easy as replacing the ELWL transceiver with a DWDM transceiver. Instead of being connected directly to the line fiber, the individual DWDM signal channels are connected by a patch cable to a passive multiplexer. The multiplexer gathers all traffic signals, allows for them to be transported over the same fiber. So fiber utilization is maximized

An embedded DWDM solution offers the simplicity of the ELWL with the additional advantage that many traffic signals can be transported over the same dark fiber.

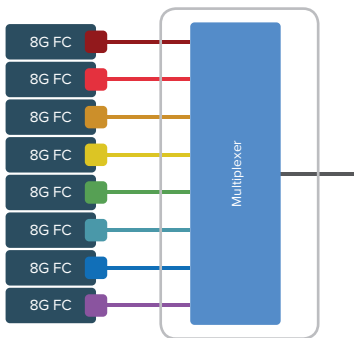

Capital expenditure

1 x Embedded DWDM system \$53,000

Operational expenditure

1 x fiber pair leasing costs \$36,000

(Based on \$1000 / month leasing cost per fiber)

TOTAL COST (Three years) \$89,000

The calculation is based on eight x 8Gbps services over a three-year fiber lease period. Thanks to the possibility of multiplexing the different channels one single fiber is needed to support eight channels of 8Gbps traffic with the embedded DWDM system.

An embedded DWDM solution offers the simplicity of the ELWL plug and play approach. Using a DWDM transceiver and multiplexer gives the additional advantage of supporting up to 80 different channels over one single dark fiber. New channels are easily added by simply adding new transceivers.. As the calculation shows, this significantly reduces the cost of the total solution over time. Since the passive, embedded system does not require any power and emits no noise it also offers a foundation for the ultimate green data center solution.

Embedded DWDM at-a-glance:

- Plug and play simplicity
- Maximum fiber optimization when used for multiple traffic channels
- New channels easily added by adding new transceivers
- Lowest TCO due to low CAPEX and OPEX

Getting the most from your dark fiber

Although there are a number of alternatives available for transporting data between sites, many are expensive and cost even more when it comes to maintenance. Even if not immediately available, it's worth trying to gain access to dark fiber so that control can be kept in the network and any operational costs can be minimized.

As the comparison between four different alternatives for transporting eight channels of 8Gbps traffic over fiber shows, using a carrier to offer the services exceeds all other alternatives by far. The total cost for this scenario is actually about \$700K over three years. At first glance single ELWL channels are simple to setup and with an attractively low cost per unit. But the operating expenses for adding multiple fiber channels increases linearly per channel. The total cost for using ELWL is \$335K. And active DWDM offers the benefit of supporting all eight services over a single pair of fibers. In spite of the high-priced carrier-grade DWDM platform, it's an attractive alternative to the ELWL approach systems after the first month. The total cost over three years is \$140K. The most beneficial scenario from a total cost of ownership is to use an embedded DWDM solution, summing up to \$86K for eight channels of 8Gbps over three years. In addition to the financial calculation, embedded DWDM offers significant benefits in terms of ease-of-use, reducing installation complexities, and operational costs for system administration and management.

8 channel solution types	price/8 Channels (USD)	Monthly Opex (USD)	price after 3 years (USD)
Carrier managed service using active DWDM	N/A	20K	710K
ELWL Solution (Usually limited to ≤40km)	47K	8,000	335K
Active transponder based DWDM system	70K	2,000	140K
Embedded Brocade approved DWDM	50K	1,000	85K

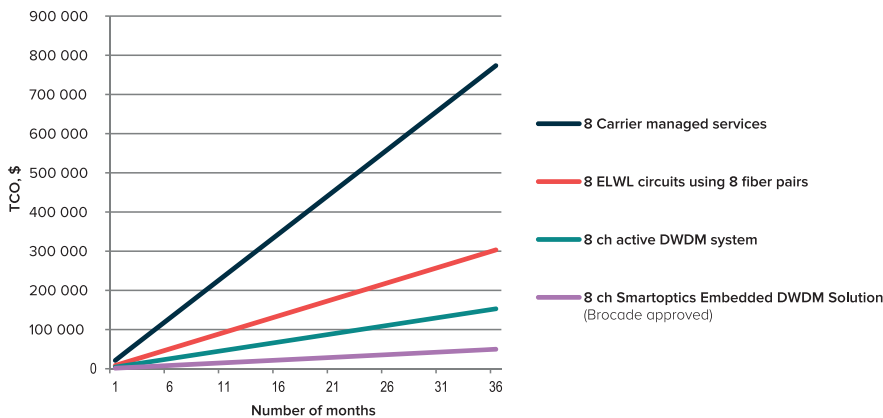

About Smartoptics

Smartoptics offers optical transmission solutions making networks more powerful. Expanding bandwidth without the upfront investment or hassle of traditional WDM. Our products allow corporate data centers, governments, hosting solution providers and ISPs to build simple, straightforward and cost effective solutions to fulfill their ongoing and future network capacity needs. Headquartered in Oslo, Norway, Smartoptics is an international provider with thousands of installations all around the world. Our award-winning approach has helped companies from every industry sector stay ahead of expanding network demands.

smartoptics

Ryengsvingen 7
0680 Oslo
Norway
+47 21 41 74 00

info@smartoptics.com
smartoptics.com